

Best Management Practices for Trapping Fisher in the United States

UPDATED 2014

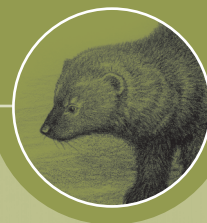



Figure FS1. Fisher (*Martes pennanti*)

Best Management Practices (BMPs) are carefully researched educational guides designed to address animal welfare and increase trappers' efficiency and selectivity. The extensive research and field-testing used to develop BMPs are described in the Introduction section of this manual. The evaluation methods used to develop BMPs have been standardized, enabling them to be easily updated and revised as new traps and techniques become available. All traps listed in the BMPs have been tested and meet performance standards for animal welfare, efficiency, selectivity, practicality and safety.

Trapping BMPs provide options, allowing for discretion and decision making in the field. BMPs are meant to be implemented in a voluntary and educational approach and do not present a single choice that can or must be applied in all cases. BMPs are the product of ongoing work that may be updated as additional traps are identified through future scientific testing.

The Fisher at a Glance

Characteristics

The fisher (*Martes pennanti*) (Figure FS1) is a member of the Mustelidae family. Like most other members of the "weasel" family, fishers have long and slender bodies, a noticeable growth of whiskers around the snout, a pointed face and relatively short, strong legs. A bushy tail makes up about one-third of the overall length, and often makes them appear much larger than they actually are. Adult males typically weigh nearly twice that of females and average about 8.5 pounds, with females averaging four to five pounds. Adult males average from 35 to 47 inches in overall length, while adult females average 29 to 37¹/₂ inches. The coat of most fishers is grayish brown to dark brown, though the fur on the rump, tail and legs is generally black. The fur on the head and shoulders may be grizzled with beautiful gold and silver coloration, especially on males. Most fisher have white colored patches on their chests and/or groin also. Fisher spend most of the time on the ground, though they are expert and agile climbers. Like other mustelids, fishers have anal scent glands that produce a pungent odor.

Range

The fisher occurs only in North America and is found throughout the northwest, northeast, and northern portions of the midwest regions of the United States. Fishers range throughout Canada from the east coast to the northwest and Yukon territories, but they are not found above the Arctic Circle.

Habitat

The fisher prefers forests with a variety of species and ages of hardwood and coniferous trees. Adequate overhead cover, provided by dense conifers, is an important habitat component during winter due to the fact that snow accumulation on the forest floor is reduced, permitting fishers to travel and hunt more efficiently. Hardwood trees are an important habitat component as well, as fishers rely on dead snags or cavities in live trees for den sites. Other important habitat components include temporary shelters and resting places such as the dens and burrows of other animals, brush piles, rock piles, hollow logs and tree cavities. Fishers spend considerable time hunting in edge habitats that contain an abundance of prey species.

Food Habits

Fishers are primarily carnivorous with opportunistic feeding habits. Their diet varies with seasonal availability. Principle prey items include snowshoe hares, mice, voles, shrews, squirrels, birds, amphibians, reptiles, fish and insects. Uniquely, fishers are known to be efficient predators of porcupines, typically killing them with repeated bites to the face and head. Fishers will consume carrion, and they seasonally feed on fruit, nuts, berries and some types of fungi.

Reproduction

The fisher breeding season occurs in early spring with March and April being the peak months. The gestation period is between 327 to 358 days, due to delayed implantation (a period of arrested embryonic growth) with young typically being born from March to early April of the following year. The average litter size is three, but varies from one to five. Female fishers reach sexual maturity by one year of age and may become pregnant in their first breeding season, giving birth at age two. Males however, are usually not successful breeders until their second year. Female fishers have one litter per year. The female fisher typically makes a maternal den high above ground in the cavity of a large tree (often an abandoned woodpecker nest) where she will give birth to her litter of young (kits). Kits are born toothless, blind and sparsely furred. Kits are moved to a ground level or subterranean den at about two months of age. By five months of age, young fishers are nearly adult sized and are capable of killing their own prey. The young remain with the female in a family unit until late summer or early fall and then disperse to establish their own territories. The rearing of young is left solely to the female.

Populations

During the early to mid-1900s, fisher numbers continued to decline across the entirety of their range due to unregulated harvest and habitat reduction. Populations rebounded in the later half of the 20th century due to conservation efforts which included numerous reintroduction projects, controlled harvest and regulated seasons. These efforts continue where good habitat still exists and fisher populations have re-colonized a significant portion of their previously known range. Their populations remain low in the northwestern United States.



3

FISHER

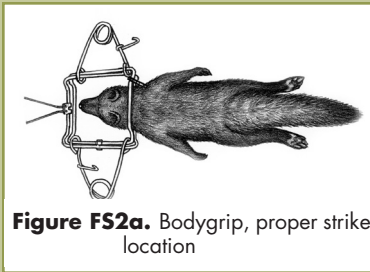

Figure FS2a. Bodygrip, proper strike location

General Overview of Traps Meeting BMP Criteria for Fisher in the United States

Three basic types of traps meet BMP criteria for fisher: cage traps, bodygrip traps and foothold traps (Table FS1). Examples, brief descriptions, and mechanical details of the various devices are given in the next section.

Trap Category	Total Dimensions* Length x Width x Height	Door Size* Width x Height	Mesh Size*/Gauge	
Cage	32 x 10 x 12.75	10 x 12	1 x 2 12 gauge galvanized	
	Height of Trap Window*	Width of Trap Window*	Frame Wire*	Spring Wire*
†Bodygrip	4 1/4 - 7	4 1/4 - 7 1/4	3/16 - 1/4	3/16 - 1/4
	Jaw/Frame Characteristics	Inside Jaw/Frame Spread at Dog*	Inside Width at Jaw/Frame Hinge Posts	
Coil-spring (foothold)	Padded	4 1/2	4 9/16	

* Inches

† All bodygrip traps tested had two springs.

General Considerations When Trapping Fisher

Cage Traps

- Can be used to capture several furbearer species
- Can be used in locations and in weather conditions where other traps are less effective
- Capture and hold animals alive, allowing for release
- Often require bait
- Are bulky

Bodygrip Traps

- Should be placed so that the rotating jaws capture the animal by closing on the top and bottom of the animal's neck (Figure FS2a)
- Can be used in locations and in weather conditions where other traps are less effective
- May not be appropriate in some areas (captures and kills animals, no release)
- May need additional protection in some areas to avoid capture of non-target animals through use of restricted entry cubby sets and elevated pole sets (Figures FS2b and FS2c)
- Often require bait

Foothold Traps

- Can be used to capture several furbearer species
- Capture and hold animals alive, allowing for release
- Use in baited cubby sets to improve selectivity

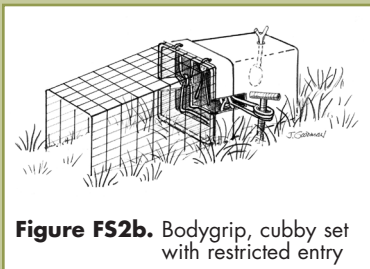

Figure FS2b. Bodygrip, cubby set with restricted entry

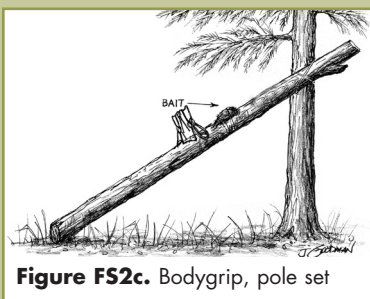

Figure FS2c. Bodygrip, pole set



Safe Use of Bodygrip Traps

By design, bodygrip traps must close with considerable force to humanely dispatch and efficiently capture wild furbearers. This is particularly true of larger sized and “magnum” type bodygrip traps. As a result, users should take special precautions to avoid potential injury when using these devices. Trappers should be familiar with the safe and efficient use of bodygrip traps and these are best learned in trapper education courses.

A setting tool (Figure FS3a) should be used to compress trap springs when setting large and magnum bodygrip traps. Use of a setting tool will not only make setting traps easier, it will make setting traps safer by allowing the trapper to keep hands and fingers away from the jaws (Figure FS3b). Most bodygrip traps that have double springs are equipped with spring latches that hold each spring compressed, and the trapper should use these latches on both trap springs. A safety gripper (Figure FS4a) should also be attached to the jaws when the jaws are moved to the set position (Figure FS4b). This will prevent the trap from accidentally closing. The above safety devices protect the trapper and make it easier to set, position and anchor the trap safely. Safety devices should be disengaged only when the set is completed.

If you are accidentally caught in a bodygrip trap you need to know how to free yourself. A setting tool is the most effective means to freeing yourself and should be used to compress the springs or jaws. You should always have one in reach when setting and placing bodygrip traps. In the event you are not able to reach one or use it with one arm, you should always carry a four foot piece of rope. The rope should have a loop tied on one end and should be stored in a pocket that can be easily accessed by either hand. You can use the rope to free yourself as follows:

- 1) Thread the rope through the eyes of one of the springs (Figure FS5a).
- 2) Bring the rope around and thread it back through the eyes a second time (Figure FS5b).
- 3) Place your foot in the looped end of the rope and pull the other end with your free hand until you can set the safety latch for that spring. (Figure FS5c).
You may need to do this to both springs to completely free yourself.

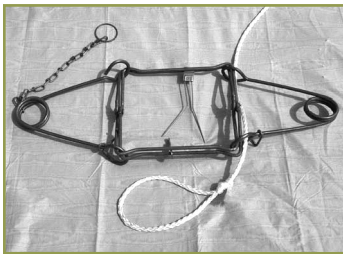

Figure FS5a. Step 1

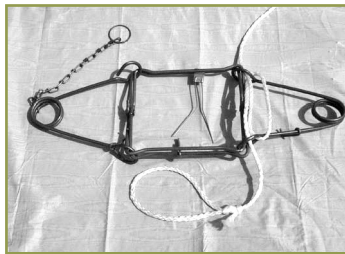

Figure FS5b. Step 2

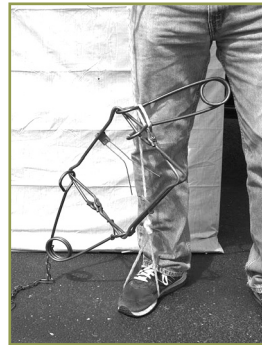

Figure FS5c. Step 3



Figure FS3a. Setting tool

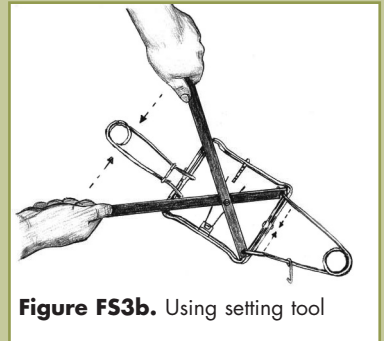

Figure FS3b. Using setting tool



Figure FS4a. Safety gripper



Figure FS4b. Using safety gripper

Specifications of Traps Meeting BMP Criteria for Fisher in the United States

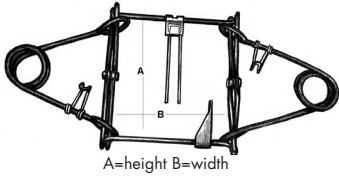

Figure FS6. Bodygrip trap

As more capture devices are tested and new information becomes available, they will be added to an updated list. Mechanical descriptions of tested traps are given as an aid to trappers or manufacturers who may wish to measure, build or modify traps to meet these specifications (Figure FS6). Also, other commercially available traps, modified traps, or other capture devices not yet tested may perform as well as, or better than the listed BMP traps. References to trap names are provided to identify the specific traps tested. This list is provided for information purposes only and does not imply an endorsement of any manufacturer.

Average mechanical measurements are rounded to the nearest $\frac{1}{16}$ inch. There may be up to a $\frac{1}{8}$ inch variation in specifications on the part of the manufacturer. Manufacturers use recognizable names, such as "No. 2" coil-spring, to identify certain traps. However, there is no standardized system linking mechanical design features with trap names. The mechanical features of these traps are listed so that similar traps may be identified.

Cage Trap (Figure FS7)

Average Mechanical Description and Attributes

Cage material, and mesh size: 12 gauge galvanized steel wire mesh, 1 x 2 inches

Cage size (length x width x height): 32 x 10 x 12.75 inches

Door size (width x height): 10 x 12 inches

Weight: 14 pounds

Model tested: Non-collapsing (rigid); single door

Door closure: Spring operated

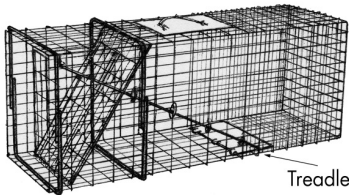

Figure FS7. Cage trap

Any trap that has similar specifications may be considered a BMP trap regardless of brand or source of modification, although performance information on all other BMP criteria (see Introduction: "Criteria for Evaluation of Trapping Devices" pages 4-6) needs to be considered as well. The trap tested was the Tomahawk™ Cage Trap, No. 108.

Additional Information

- Selectivity features: Limited opening size and length—restricts large animals.
- Special considerations for practicality: Versatile set options; can be used for multiple furbearer species in same sets; large and easily seen (difficult to conceal completely); bulky—requires space for transport and storage; captured animals are easily released; continues to operate in freezing weather conditions when placed in a cubby. This device also meets BMP criteria for raccoons, gray foxes and opossums.

Bodygrip Traps (Figures FS8, FS9 FS10 and FS11)

Average Mechanical Description and Attributes

Height of trap window: 4 ⁷/₈ inches

Width of trap window: 4 ⁵/₈ inches

Diameter of frame wire: ³/₁₆ inch

Diameter of spring wire: ³/₁₆ inch

Additional clamping bar: None, but does have a magnum bend which eliminates the gap between the jaws when the trap is closed.

Safety features: Spring latches

Any trap that has similar specifications may be considered a BMP trap regardless of brand or source of modification, although performance information on all other BMP criteria (see Introduction: "Criteria for Evaluation of Trapping Devices" pages 4-6) needs to be considered as well. The trap tested was the Belisle™ Super X 120 bodygrip trap.

Additional Information

- Anchoring used in trap testing: 18 inch cable, anchored with a stake.
- Selectivity features: Due to limited opening size, this trap may selectively capture small, likely female, fisher.
- Safety considerations: This trap has complete jaw closure. The use of safety devices such as setting tongs and a safety gripper is highly recommended, and trappers should familiarize themselves with emergency release methods discussed in the "Safe Use of Bodygrip Traps" section.
- Special considerations for practicality: Versatile set options (cubby sets, leaning pole sets); can be used for multiple furbearer species in same sets; continues to operate in freezing weather conditions (when placed in a cubby). This device also meets BMP criteria for marten and muskrat.



Average Mechanical Description and Attributes

Height of trap window: 6 ¹/₈ inches

Width of trap window: 6 ¹/₄ inches

Diameter of frame wire: ³/₁₆ inch

Diameter of spring wire: ³/₁₆ inch

Additional clamping bar: None, but does have a magnum bend which eliminates the gap between the jaws when the trap is closed.

Safety features: Spring latches

Any trap that has similar specifications may be considered a BMP trap regardless of brand or source of modification, although performance information on all other BMP criteria (see Introduction: "Criteria for Evaluation of Trapping Devices" pages 4-6) needs to be considered as well. The trap tested was the Belisle™ Super X 160 bodygrip trap.

Additional Information

- Anchoring used in trap testing: 18 inch cable, anchored with a stake.
- Safety considerations: This trap has complete jaw closure. The use of safety devices such as setting tongs and a safety gripper is highly recommended, and trappers should familiarize themselves with emergency release methods discussed in the "Safe Use of Bodygrip Traps" section.
- Special considerations for practicality: Versatile set options (cubby sets, leaning pole sets); can be used for multiple furbearer species in same sets; continues to operate in freezing weather conditions (when placed in a cubby). This device also meets BMP criteria for raccoons.

Most bodygrip traps approved in this BMP were tested via computer simulation modeling relative to animal welfare performance. As a result, trap anchoring information does not exist for these traps. However, bodygrip traps should always be securely anchored. Anchoring information is provided on specific traps that were field tested.

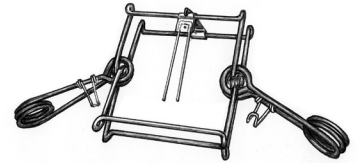

Figure FS8. Belisle™ Super X bodygrip (set)

Average Mechanical Description and Attributes

Height of trap window: 6 ⁷/₈ inches

Width of trap window: 7 ¹/₄ inches

Diameter of frame wire: ¹/₄ inch

Diameter of spring wire: ¹/₄ inch

Additional clamping bar: None, but does have a magnum bend which eliminates the gap between the jaws when the trap is closed.

Safety features: Spring latches

Any trap that has similar specifications may be considered a BMP trap regardless of brand or source of modification, although performance information on all other BMP criteria (see Introduction: "Criteria for Evaluation of Trapping Devices" pages 4-6) needs to be considered as well. The trap tested was the Belisle™ Super X 220 bodygrip trap.

Additional Information

- Safety considerations: This trap has complete jaw closure. The use of safety devices such as setting tongs and a safety gripper is highly recommended, and trappers should familiarize themselves with emergency release methods discussed in the "Safe Use of Bodygrip Traps" section.
- Special considerations for practicality: Versatile set options (cubby sets, leaning pole sets); can be used for multiple furbearer species in same sets; continues to operate in freezing weather conditions (when placed in a cubby). This device also meets BMP criteria for raccoon; and for beaver, river otter and muskrat in submersion sets.



Average Mechanical Description and Attributes

Height of trap window: 6 inches

Width of trap window: 6 ¹/₁₆ inches

Diameter of frame wire: ³/₁₆ inch

Diameter of spring wire: ³/₁₆ inch

Additional clamping bar: Yes

Safety features: Spring latches

Any trap that has similar specifications may be considered a BMP trap regardless of brand or source of modification, although performance information on all other BMP criteria (see Introduction: "Criteria for Evaluation of Trapping Devices" pages 4-6) needs to be considered as well. The trap tested was the LDL™ C160 Magnum bodygrip trap.

Additional Information

- Safety considerations: This trap has complete jaw closure. The use of safety devices such as setting tongs and a safety gripper is highly recommended, and trappers should familiarize themselves with emergency release methods discussed in the "Safe Use of Bodygrip Traps" section.
- Special considerations for practicality: Versatile set options (cubby sets, leaning pole sets); can be used for multiple furbearer species in same sets; continues to operate in freezing weather conditions (when placed in a cubby).

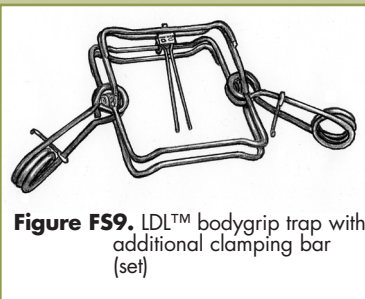

Figure FS9. LDL™ bodygrip trap with additional clamping bar (set)

Average Mechanical Description and Attributes

Height of trap window: 7 inches

Width of trap window: 7 ¹/₁₆ inches

Diameter of frame wire: ¹/₄ inch

Diameter of spring wire: ¹/₄ inch

Additional clamping bar: Yes

Safety features: Spring latches

Any trap that has similar specifications may be considered a BMP trap regardless of brand or source of modification, although performance information on all other BMP criteria (see Introduction: "Criteria for Evaluation of Trapping Devices" pages 4-6) needs to be considered as well. The trap tested was the LDL™ C 220 Magnum bodygrip trap.

Additional Information

- Safety considerations: This trap has complete jaw closure. The use of safety devices such as setting tongs and a safety gripper is highly recommended, and trappers should familiarize themselves with emergency release methods discussed in the "Safe Use of Bodygrip Traps" section.
- Special considerations for practicality: Versatile set options (cubby sets, leaning pole sets); can be used for multiple furbearer species in same sets; continues to operate in freezing weather conditions (when placed in a cubby). This device also meets BMP criteria for raccoon; and for beaver, river otter and muskrat in submersion sets.



Average Mechanical Description and Attributes

Height of trap window: 6 inches

Width of trap window: 5 ³/₄ inches

Diameter of frame wire: ¹/₄ inch

Diameter of spring wire: ³/₁₆ inch

Additional clamping bar: None

Safety features: Spring latches

Any trap that has similar specifications may be considered a BMP trap regardless of brand or source of modification, although performance information on all other BMP criteria (see Introduction: "Criteria for Evaluation of Trapping Devices" pages 4-6) needs to be considered as well. The trap tested was the Rudy™ 160 Plus bodygrip trap.

Additional Information

- Safety considerations: Use of setting tongs and safety gripper is recommended.
- Special considerations for practicality: Versatile set options (cubby sets, leaning pole sets); can be used for multiple furbearer species in same sets; continues to operate in freezing weather conditions (when placed in a cubby). This device also meets BMP criteria for marten and raccoon.



Average Mechanical Description and Attributes

Height of trap window: 4 1/4 inches

Width of trap window: 4 1/4 inches

Diameter of frame wire: 1/4 inch

Diameter of spring wire: 3/16 inch

Additional clamping bar: Yes

Safety features: Spring latches

Any trap that has similar specifications may be considered a BMP trap regardless of brand or source of modification, although performance information on all other BMP criteria (see Introduction: "Criteria for Evaluation of Trapping Devices" pages 4-6) needs to be considered as well. The trap tested was the Rudy™ 120 Magnum bodygrip trap.

Additional Information

- Selectivity features: Due to limited opening size this trap may selectively capture small, likely female, fisher.
- Safety considerations: This trap has complete jaw closure. The use of safety devices such as setting tongs and a safety gripper is highly recommended, and trappers should familiarize themselves with emergency release methods discussed in the "Safe Use of Bodygrip Traps" section.
- Special considerations for practicality: Versatile set options (cubby sets, leaning pole sets); can be used for multiple furbearer species in same sets; continues to operate in freezing weather conditions (when placed in a cubby). This device also meets BMP criteria for marten.



Average Mechanical Description and Attributes

Height of trap window: 5 inches

Width of trap window: 4 1/2 inches

Diameter of frame wire: 3/16 inch

Diameter of spring wire: 1/4 inch

Additional clamping bar: Yes

Safety features: Spring latches

Any trap that has similar specifications may be considered a BMP trap regardless of brand or source of modification, although performance information on all other BMP criteria (see "Criteria for Evaluation of Trapping Devices": Introduction pages 4-6) needs to be considered as well. The trap tested was the Sauvageau™ C120 Magnum bodygrip trap.

Additional Information

- Selectivity features: Due to limited opening size, this trap may selectively capture small, likely female, fisher.
- Safety considerations: This trap has complete jaw closure. The use of safety devices such as setting tongs and a safety gripper is highly recommended, and trappers should familiarize themselves with emergency release methods discussed in the "Safe Use of Bodygrip Traps" section.
- Special considerations for practicality: Versatile set options (cubby sets, leaning pole sets); can be used for multiple furbearer species in same sets; continues to operate in freezing weather conditions (when placed in a cubby). This trap also meets BMP criteria for marten and muskrat.

Average Mechanical Description and Attributes

Height of trap window: 5 inches
Width of trap window: 4 1/2 inches
Diameter of frame wire: 3/16 inch
Diameter of spring wire: 3/16 inch
Additional clamping bar: Yes
Safety features: Spring latches

Any trap that has similar specifications may be considered a BMP trap regardless of brand or source of modification, although performance information on all other BMP criteria (see Introduction: "Criteria for Evaluation of Trapping Devices" pages 4-6) needs to be considered as well. The trap tested was the Sauvageau™ 2001-5 bodygrip trap.

Additional Information

- Selectivity features: Due to limited opening size this trap may selectively capture small, likely female, fisher.
- Safety considerations: This trap has complete jaw closure. The use of safety devices such as setting tongs and a safety gripper is highly recommended, and trappers should familiarize themselves with emergency release methods discussed in the "Safe Use of Bodygrip Traps" section.
- Special considerations for practicality: Versatile set options (cubby sets, leaning pole sets); can be used for multiple furbearer species in same sets; continues to operate in freezing weather conditions (when placed in a cubby). This device also meets BMP criteria for marten and muskrat.



Average Mechanical Description and Attributes

Height of trap window: 6 inches
Width of trap window: 6 inches
Diameter of frame wire: 3/16 inch
Diameter of spring wire: 3/16 inch
Additional clamping bar: Yes
Safety features: Spring latches

Any trap that has similar specifications may be considered a BMP trap regardless of brand or source of modification, although performance information on all other BMP criteria (see Introduction: "Criteria for Evaluation of Trapping Devices" pages 4-6) needs to be considered as well. The trap tested was the Sauvageau™ 2001-6 bodygrip trap.

Additional Information

- Safety considerations: This trap has complete jaw closure. The use of safety devices such as setting tongs and a safety gripper is highly recommended, and trappers should familiarize themselves with emergency release methods discussed in the "Safe Use of Bodygrip Traps" section.
- Special considerations for practicality: Versatile set options (cubby sets, leaning pole sets); can be used for multiple furbearer species in same sets; continues to operate in freezing weather conditions (when placed in a cubby). This device also meets BMP criteria for raccoon.



Figure FS10. Sauvageau™ bodygrip trap with additional clamping bar (set)



Average Mechanical Description and Attributes

Height of trap window: 7 inches

Width of trap window: 7 inches

Diameter of frame wire: $\frac{1}{4}$ inch

Diameter of spring wire: $\frac{1}{4}$ inch

Additional clamping bar: Yes

Safety features: Spring latches

Any trap that has similar specifications may be considered a BMP trap regardless of brand or source of modification, although performance information on all other BMP criteria (see Introduction: "Criteria for Evaluation of Trapping Devices" pages 4-6) needs to be considered as well. The trap tested was the Sauvageau™ 2001-7 bodygrip trap.

Additional Information

- Safety considerations: This trap has complete jaw closure. The use of safety devices such as setting tongs and a safety gripper is highly recommended, and trappers should familiarize themselves with emergency release methods discussed in the "Safe Use of Bodygrip Traps" section.
- Special considerations for practicality: Versatile set options (cubby sets, leaning pole sets); can be used for multiple furbearer species in same sets; continues to operate in freezing weather conditions (when placed in a cubby). This device also meets BMP criteria for raccoon.



Average Mechanical Description and Attributes

Height of trap window: $6 \frac{3}{4}$ inches

Width of trap window: $7 \frac{1}{4}$ inches

Diameter of frame wire: $\frac{1}{4}$ inch

Diameter of spring wire: $\frac{1}{4}$ inch

Additional clamping bar: None, but does have a magnum bend which eliminates the gap between the jaws when the trap is closed.

Safety features: Spring latches

Any trap that has similar specifications may be considered a BMP trap regardless of brand or source of modification, although performance information on all other BMP criteria (see Introduction: "Criteria for Evaluation of Trapping Devices" pages 4-6) needs to be considered as well. The trap tested was the Rudy™ 220 Plus bodygrip trap.

Additional Information

- Anchor trap securely.
- Safety considerations: This trap has complete jaw closure. The use of safety devices such as setting tongs and a safety gripper is highly recommended, and trappers should familiarize themselves with emergency release methods discussed in the "Safe Use of Bodygrip Traps" section.
- Special considerations for practicality: Versatile set options (cubby sets, leaning pole sets); can be used for multiple furbearer species in same sets; continues to operate in freezing weather conditions (when placed in a cubby). This device also meets BMP criteria for raccoons and river otter.



Figure FS11.

Foothold Traps (Figures FS12 and FS13)

Average Mechanical Description and Attributes

Inside jaw spread (at dog): 4 1/2 inches

Inner width: 4 7/8 inches

Inside width at jaw hinge posts: 4 9/16 inches

Jaw width: 9/16 inch padded jaw

Jaw thickness: 3/8 inch

Padding: Manufacturer supplied rubber pads

Main trap springs: Two 0.131 inch wire-diameter coil springs

Additional springs: Two 0.100 inch wire-diameter coil springs

Base plate: Reinforced with D-ring

Any trap that has similar specifications may be considered a BMP trap regardless of brand or source of modification, although performance information on all other BMP criteria (see "Criteria for Evaluation of Trapping Devices": Introduction pp. 4-6) needs to be considered as well. The trap tested was the Woodstream™ Victor No. 1 1/2 Softcatch modified coil-spring, four-coiled.

Additional Information

- Chain attachment used in trap testing: 7 1/2 inch, center mounted with two swivels, one shock spring and anchored with a stake.
- Selectivity features: Brass pan tension machine screw; pan tension was set to two pounds for testing, and checked and readjusted as needed after every capture.
- Special considerations for practicality: Some damage to trap pads should be expected and will require occasional replacement as a normal part of trap maintenance and upkeep. Special care should be taken to prevent odor contamination of the rubber jaws. Avoid using petroleum-based dye directly on the rubber pads. This device also meets BMP criteria for bobcat, Eastern coyote, gray fox, opossum and red fox.

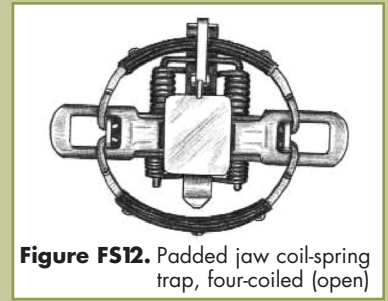

Figure FS12. Padded jaw coil-spring trap, four-coiled (open)

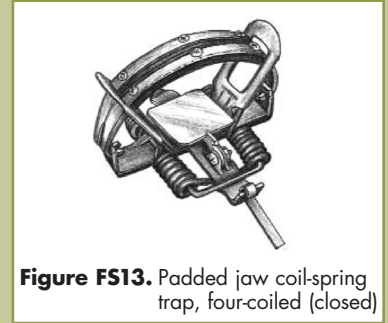

Figure FS13. Padded jaw coil-spring trap, four-coiled (closed)