

2017

Bodygrip Traps on Dryland: A Guide to Responsible Use



**ASSOCIATION *of*
FISH & WILDLIFE
AGENCIES**

Furbearer Conservation
Technical Work Group

Table of Contents

Acknowledgements	2
Introduction	3
History: Bodygrip Trap or Conibear?	4
Trap Research	6
Trap Set Location	7
Bait and Lure Use	9
Trap Size	10
Trigger Type, Position and Shape	11
Trap Set Type	13
Other Considerations	17
Hunter Awareness	18
Conclusion	18
References	19

Acknowledgements

This document was produced by the Association of Fish and Wildlife Agencies (AFWA) Furbearer Conservation Technical Work Group, in consultation with representatives from trapping organizations. We especially acknowledge Matt Peek of the Kansas Department of Wildlife, Parks and Tourism for serving as primary author on this document. Significant contributions in authorship were also made by Dave Hastings of the Fur Takers of America and Matt Lovallo of the Pennsylvania Game Commission. We wish to acknowledge Bob Noonan for writing the history of the bodygrip trap section based on his knowledge and conversations with Neal Jotham, Fur Institute of Canada. We also acknowledge members of the Furbearer Conservation Technical Work Group, who reviewed this document, as well as Dr. Tim Hiller who assisted with an early version of the document. Illustration credits are to Joe Goodman. Photo credits to Austin Worth (Missouri Department of Conservation), Bryant White (AFWA), eXtension.org, Matt Peek (Kansas Department of Wildlife, Parks and Tourism), Maine Department of Inland Fisheries and Wildlife and New York State Department of Environmental Conservation. We would also like to acknowledge the document "Safe and Ethical Use of the Dryland Conibear Trap" that served as a guide for this document (Wisconsin Trappers Association 1998).

Foreword

This document, *Bodygrip Traps on Dryland: A Guide to Responsible Use*, is primarily intended to be a reference guide summarizing techniques and recommendations for improving the selectivity of bodygrip traps. Policy-makers and other interested individuals will find the information valuable for making informed decisions about bodygrip trap use. We hope this document is also a useful addition to trapper education programs. Although this document contains the best available information on methods to improve selectivity of bodygrip traps, there have been few formal studies on the effects of these methods on trap selectivity or efficiency. As such, we hope this document stimulates additional research and development of bodygrip trap systems. Depiction of, or reference to, specific traps does not constitute a recommendation or endorsement by the Association of Fish and Wildlife Agencies. This document may be updated periodically, and updates will be posted on the AFWA website at www.fishwildlife.org/furbearer_management.

Introduction

Regulated trapping of furbearers provides a wide range of benefits to society. Furbearers are trapped for damage and population control, to protect sensitive habitats, for research and reintroductions, and to promote endangered species (see White et al. 2015). For most trappers, trapping is an important part of an outdoor lifestyle practiced in many rural communities where members participate in fishing, hunting, gardening, firewood collection and other activities that use natural resources in a self-sufficient and sustainable manner.

Modern trapping is regulated by state wildlife agencies as part of science-based furbearer management programs. These programs ensure that furbearer populations are not depleted, that trapping techniques are socially acceptable and humane, and that harvesting the species serves a useful purpose (White et al. 2015).

Most traps can be categorized into one of four general types: foothold traps, bodygrip traps, snares (including cable restraints), or cage traps. Each trap type has advantages and disadvantages under certain circumstances, and no single trap type is ideal in all situations. For example, most canines can not be efficiently captured in cage traps, and foothold traps can be difficult to keep operational in certain weather conditions. For maximum efficiency, trappers need all four trap types at their disposal so they can select the appropriate one for the situation at hand.

Bodygrip traps are the newest of the four major trap types. They were developed by Canadian trapper Frank Conibear, who recognized a need for a humane, efficient, lethal trap (see "History" section, pg. 4). Bodygrip traps are favorable to trappers under many circumstances (see box below, pg. 5), and once commercially available, these traps quickly became very popular. Today, they are the most popular trap type for some species (see box below). But the ability of these traps to quickly kill target animals, which makes them so popular, also creates its own set of challenges.

When nontarget animals are captured in bodygrip traps, they also are often killed. In some states that allow medium-sized bodygrip traps on dryland, incidental capture of nontargets, especially dogs, has become a concern. This issue often reflects negatively upon trappers and trapping, causes contention between hunters and trappers, and has even led to the loss of certain trapping privileges in some jurisdictions. The continued use of bodygrip traps is dependent upon public support, and this support cannot be maintained without minimizing the capture of pets and protected wildlife in these devices.

Fortunately, there are ways bodygrip traps can be used to help avoid these conflicts. This guide provides information and techniques developed by experienced trappers and wildlife biologists. The objective is to help trappers maintain a high level of effectiveness with bodygrip traps while becoming more selective. That is, to effectively capture their target furbearer species but effectively avoid nontarget domestic animals and wildlife. This guide is specifically focused on the use of bodygrip traps on dryland.

The importance of bodygrip traps in the U.S.

According to a survey of trappers conducted in 2005 (Responsive Management 2005): The average trapper owned fifty bodygrip traps, including twelve #160 or #220 sized traps. Considering the total estimated number of trappers, total ownership of bodygrip traps in the U.S. can be estimated at over seven million. A similar survey of trappers conducted in 2015 (Responsive Management 2015) found 60 percent of all trappers used bodygrip traps and bodygrip traps were the most commonly used trap type to capture beaver, fisher, marten, mink, muskrat, river otter and wolverine.

The percent of trappers who listed a bodygrip trap as a trap type they usually use for various species are as follows (only species over 3 percent listed):

- River otter 86%
- Beaver 85%
- Fisher 80%
- Muskrat 76%
- Marten 70%
- Mink 70%
- Wolverine 64%
- Raccoon 24%
- Weasel 22%
- Opossum 20%
- Skunk 19%
- Nutria 17%
- Badger 14%
- Canada Lynx 12%
- Bobcat 8%
- Ringtail 8%

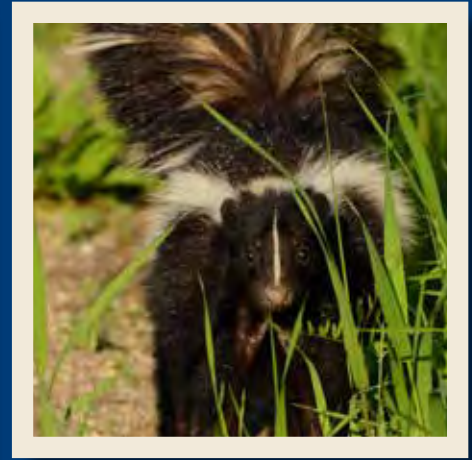
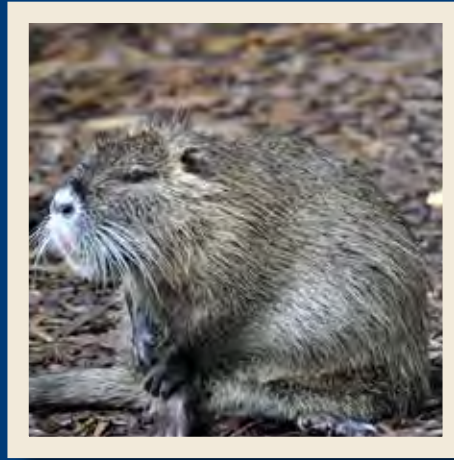

History: Bodygrip Trap or Conibear?

Wildlife researchers often refer to rotating-jaw traps as bodygrip traps, whereas trappers often apply the brand name Conibear® to describe this group of traps regardless of the manufacturer. Conibear is actually a reference to Frank Conibear (1896–1984), a Canadian trapper of English descent, who is credited with inventing this type of trap. Since its commercial introduction in 1958, no trap has had such a profound influence on trapping in recent times. However, the path to development by Mr. Conibear was not an easy one.

The Conibear family moved from England to Ontario, Canada when Frank was very young, and later to the Northwest Territories. In Canada, he learned trapping skills, including some from local natives. Footholds were the most commonly used traps in those days, but Conibear desired a trap that quickly dispatched furbearers. Over several years, including during his service in World War I and during nights on his wilderness traplines, Conibear sought to develop a trap design that was inspired by mechanisms such as eggbeaters and revolving doors in buildings.

In the mid-1920s, public attacks against the steel trap intensified. As a trapper who depended on his catch to support his family, Conibear was well aware that any new trap would have to be at least as efficient at making catches as the foothold, or it would never be accepted. In 1929, he took his model to a machine shop in Edmonton, Alberta, and had three dozen tempered steel replicas made. These were a smaller version, probably for mink, marten, and muskrat. These first traps were rectangular in shape, taller than wide, and were fired by a pan trigger. The jaws were made of flat steel, and the spring was on top, so the jaws struck the catch laterally, on the sides. Testing on his trapline resulted in failure because of poor efficiency and weak springs. Conibear felt confident that he was on the right track, but financial constraints existed. Some progress was made after the Great Depression through a private donation to Conibear, but then development and testing were idle for about two decades.

In 1944, Conibear left his trapline and moved to Victoria, British Columbia, to work as a carpenter. At about the same time, yet another non-profit group of volunteers, The Association for Protection of Furbearing Animals, was forming to promote humane trapping. Through an association with another trapper, this group was urged to assist Conibear develop his new trap design further. By 1953, this group approached the British Columbia Trappers Association, asking for volunteers to test Conibear's latest trap. In 1955, testing revealed that a new trigger system was in order, and with help, an ingenious single-trigger bar that had a four-way action and could be set in any position on the jaws was developed. By 1956, trap testing primarily for mink and marten showed that this latest design killed quickly and was at least as efficient as footholds. New sizes were also being developed and in 1957, two articles were published in the popular American magazine, *Outdoor Life*, about these new traps.



Frank Conibear, inventor of the "Conibear" or bodygrip trap.



Public interest in the new Conibear trap was very high. Interestingly, Conibear was unable to find a Canadian manufacturer for his trap and eventually sold his design to an American company, Animal Trap Company of Lititz, Pennsylvania (later Woodstream). In 1958, the first #110 Conibears appeared on the market. They were incredibly popular, and the #220 and #330 sizes soon followed. Apparently, the original design included trap jaws that closed tightly, but Animal Trap Company feared lawsuits and added a gap of almost an inch to prevent tightly pinching fingers. The larger spring eyes also let the spring slip out around the jaw ends. These two factors almost completely eliminated any clamping force against the animal, essentially changing it from a lethal trap to a restraining device.

Funding for additional research and development came through royalties supplied by Conibear as well as the Canadian Federation of Humane Societies and the Canadian Association for Humane Trapping. These studies were conducted first at McMaster University in Hamilton, Ontario, and later at the University of Guelph in Guelph, Ontario. Among other improvements, this research led to the development of the jawend loops, which increase clamping force and prevent the spring end loops from slipping out around the jaw corners. This design was provided to Woodstream in 1973. By then, the Conibear trap was almost universally accepted as a humane, lethal trap. Animal welfare groups had been very involved in financing and encouraging its development. Conibear even received an award for his trap from the American Humane Society. Despite these collaborative efforts, Conibear was especially puzzled when these animal rights groups began to work on banning all traps. All his life he had an intense mission to develop a humane lethal trap. He and the people he worked with succeeded to the point that the Conibear is now an essential tool in the trapping industry. Research on the Conibear trap goes on, and improvements continue to be made.



Why do trappers sometimes prefer to use traps that kill?

When the intent is ultimately to kill the captured animal, traps set to quickly kill are often considered preferable to restraining (live) sets for the following reasons:

- They are humane. They kill quickly, and minimize the amount of time an animal is liverestrained.
- They are very effective at capturing furbearers. Captured animals rarely escape, and these traps are sometimes used as an alternative to other trap types to which an animal has already become exposed and wary (trap-shy).
- They remain functional in adverse weather conditions in which other trap types become inoperable.
- A dead animal is less likely to be detected by passersby, making the animal and trap less susceptible to tampering or theft.
- They are very efficient to use because sets can be quickly made and the trapper doesn't have to spend time at the set to dispatch the captured animal. In some states, trappers are allowed extra time between trap checks for lethal traps or sets.

Trap Research

The international community recognized the importance, need and value of bodygrip traps enough to establish international performance standards in 1998 (ISO TC191 1998). Since that time, a considerable amount of scientific research has been conducted on the performance of bodygrip traps through both the U.S. Best Management Practices (BMPs) for trapping (see sidebar) and the Canadian Agreement on International Humane Trapping Standards (AIHTS).

Most of the mechanical testing and research on bodygrip traps has been conducted at the Alberta Research Council and Alberta Innovates Technologies facilities in Canada. Their approach follows an internationally agreed-upon killing trap test protocol (ISO 10990-4 1999). Data is collected on trap mechanical attributes and resulting performance for a given species, then computer simulation models are developed to predict performance of additional trap designs. Trap optimization routines are also developed to assist trap manufacturers by suggesting modifications for traps to improve their performance.

Given the availability of animal welfare data from Canadian testing, field testing of bodygrip traps in the United States has focused on measuring efficiency and selectivity of various designs. Bodygrip and other lethal traps are evaluated with the same five criteria as restraining traps (animal welfare, efficiency, selectivity, practicality, and safety), but killing traps must meet different performance standards for animal welfare and safety. In the U.S. BMP trap research program, the animal welfare performance standard for killing traps set on land is that the trap must cause irreversible loss of consciousness in 70 percent of the sample animals within 300 seconds.

Killing traps must meet two additional performance standards for safety. First, a trapper must be able to self-release from a trap without assistance from another person. And second, the forces generated by the trap should not be likely to cause significant human injury. Other performance standards for commonly used killing devices are comparable to those described for restraining devices, including that 60 percent of the target animals that spring the trap must be captured and held (efficiency), the trap must be able to be set and used in a manner that limits the risk of capturing non-furbearers (selectivity), and the traps should be practical for use in the field under trapline conditions (practicality).



Trapping BMPs.

In 1996, the Association of Fish and Wildlife Agencies (AFWA) began one of the most ambitious research projects in the history of conservation: a program to develop Best Management Practices (BMPs) for trapping in the United States. The program aims to improve and modernize the technology of trapping through research that evaluates animal welfare, identifies efficient traps and techniques, and promotes the very best technology available to trap wildlife. To date, BMPs for twenty-two species have been produced. An online trapper education program and a national fur harvest database have also come to fruition recently. The AFWA Furbearer Management website provides access to these resources.

http://fishwildlife.org/?section=best_management_practices

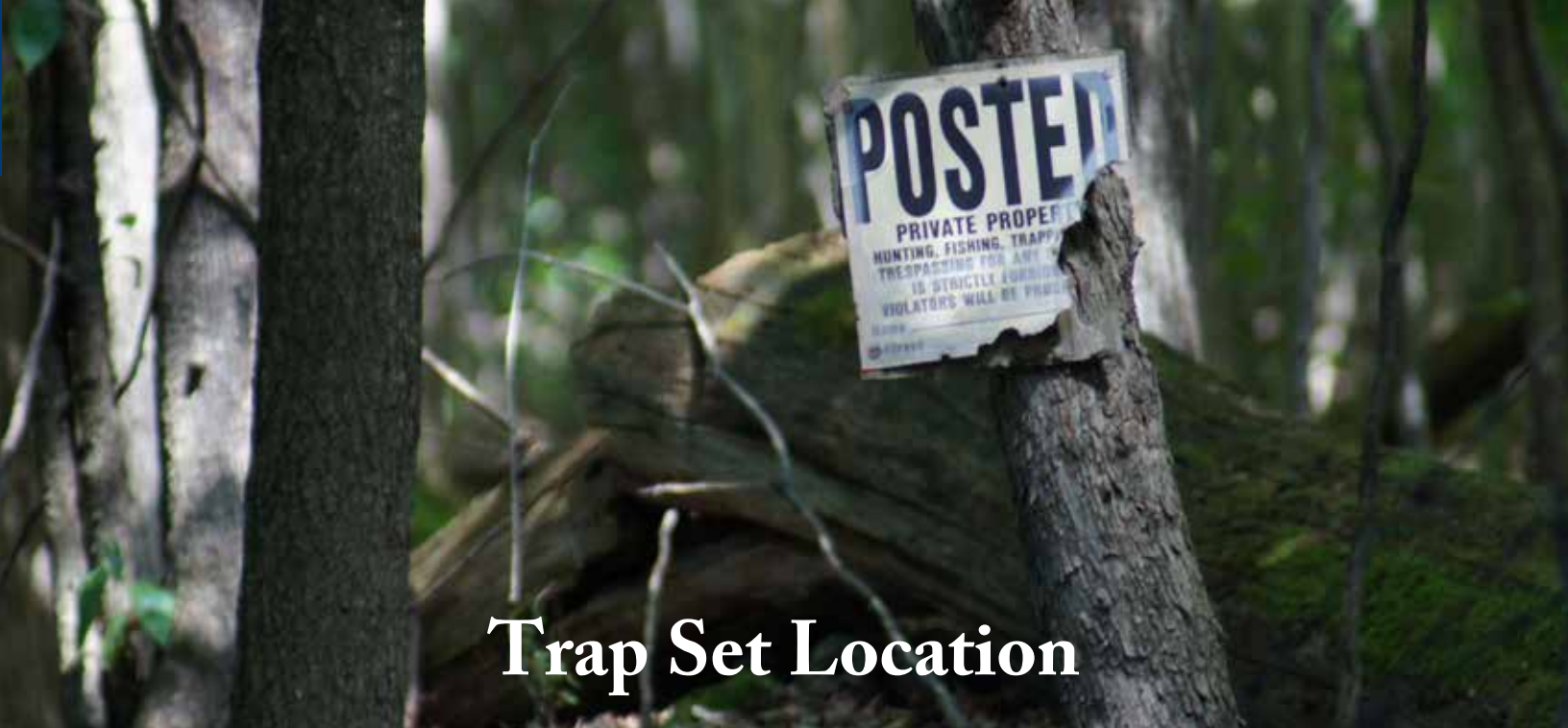

Trap Set Location

A successful trapper needs to be able to identify the areas where furbearers are going to be based on sign and habitat features. To be selective, the trapper must also be able to identify areas where nontarget animals are likely to be. When these situations are encountered, the use of techniques that make bodygrip traps more selective, such as certain baits and set types, may be sufficient. However, in certain situations, setting a live restraint trap, such as foothold trap, cage trap or cable restraint snare, or not setting a trap at all might be more appropriate.

In some states, regulations prohibit traps within a certain distance of areas considered to be high-risk. Even where regulations address some locations, trappers have a lot of leeway to use their judgment in selection and placement of trap sets, and ultimately this issue comes down to trapper discretion. Through education and outreach, trappers need to realize that their ability to legally use bodygrip traps in the right locations is dependent upon their willingness to also not use them in the wrong locations.

Below are some locations where nontarget captures and associated conflicts are more likely to occur. Some states already prohibit traps within a certain distance of these areas due to the increased risk, and several recent incidents in these areas are reminders of just how problematic they can be. It is worth noting that in some states, there may be a strong tradition to trapping these areas (i.e. roadsides or public lands), and trappers may use these areas with little conflict. However, trappers everywhere should recognize the potential for risk associated with these areas, and use caution in deciding whether and how to set them.

Sign of people, pets, or protected species

The ability to scout and read sign is essential not only to locating furbearers but also to avoiding nontarget captures and associated conflicts. Sign indicating the presence of people, pets and nontarget wildlife is an indication of what was there and what may be there again.

Near houses

Houses are the origin of the pets a trapper needs to avoid. Even where leash laws exist, a trapper should distance his sets from any dwelling.



Landowner permission and communication

One must have permission to legally trap on private land in most states, but when it comes to using dryland bodygrip traps, just having permission isn't enough. Trappers should recognize that if they were given access, the landowner will probably allow access to others as well, including hunters. Trappers should always 1) find out whether anyone else has access to the land, 2) make the landowner aware of their intent to use bodygrip traps, and 3) make sure the landowner understands the need to keep people with dogs off the property while bodygrip traps are being used.

Letting the landowner know about these traps so others can be forewarned could help avoid an uncomfortable after-the-fact explanation, should an incident occur. Failure to be forthright may also cause the trapper to lose favor with the landowner and jeopardize permission to trap the land. A little communication in this regard can go a long way towards avoiding conflict.



Roadways

Bicyclists, joggers and walkers are often accompanied by dogs. Sets that are close to the road may attract such dogs. Roads also serve as travelways for unaccompanied pets.

Property boundaries

Landowner permission may be granted for one side of the property line, but the adjacent landowner or those to whom he has granted permission may very well be accompanied by pets or hunting dogs on the other side. Conflict may be particularly likely when a travelway, such as a field road, borders the property, or when an area conducive to hunting, such as a hedge row or brushy field edge, makes up at least part of the property line on the opposite side.

Public lands

The amount of public land and its intensity of use varies by state. However, hunting dogs must be considered when trapping these lands. Hounds and bird dogs should always be a consideration on public areas, but one needs to consider the smaller dog breeds as well, such as beagles used in rabbit hunting and curs and terriers that have become popular squirrel dogs.

Because recreational activities and intensity of use vary across public lands, it's difficult to specifically identify where on public lands dryland bodygrip traps are appropriate. A general concept is they should only be set where dogs aren't going to be. Obvious locations to avoid include designated parking areas and maintained trails that may be used by hunters and perhaps even hikers and joggers on some areas. Trappers should keep in mind that dogs have a keen sense of smell and may detect baits or lures quite some distance from the parking area or trail.

Some knowledge of the area and the timing of hunting seasons or other peak recreational use is helpful in identifying less obvious locations to avoid, like heavily hunted grain fields during upland game seasons or popular brushy draws during rabbit season. Trappers should also be encouraged to use caution with bodygrip traps during general times of increased hunting pressure, like at the beginning of game bird seasons, and during holidays, plus there might be local tendencies like the increased use by grouse hunters the first two weeks after leaf fall. The local wildlife biologist or game warden may be able to help identify times and areas to avoid, based on when and where most hunting activity occurs, but there is no substitute for having good personal knowledge of the activities that occur in the areas trapped.

Despite the best of intentions, the difficulty of using bodygrip traps on public lands is that one can never be certain where a hunter or other recreationist may be. Incidents have occurred even in remote areas where the trapper chose the location cautiously in an effort to avoid other users. Therefore, additional precautions like use of selective set types, baits and smaller trap sizes are usually recommended when using bodygrip traps on public lands.



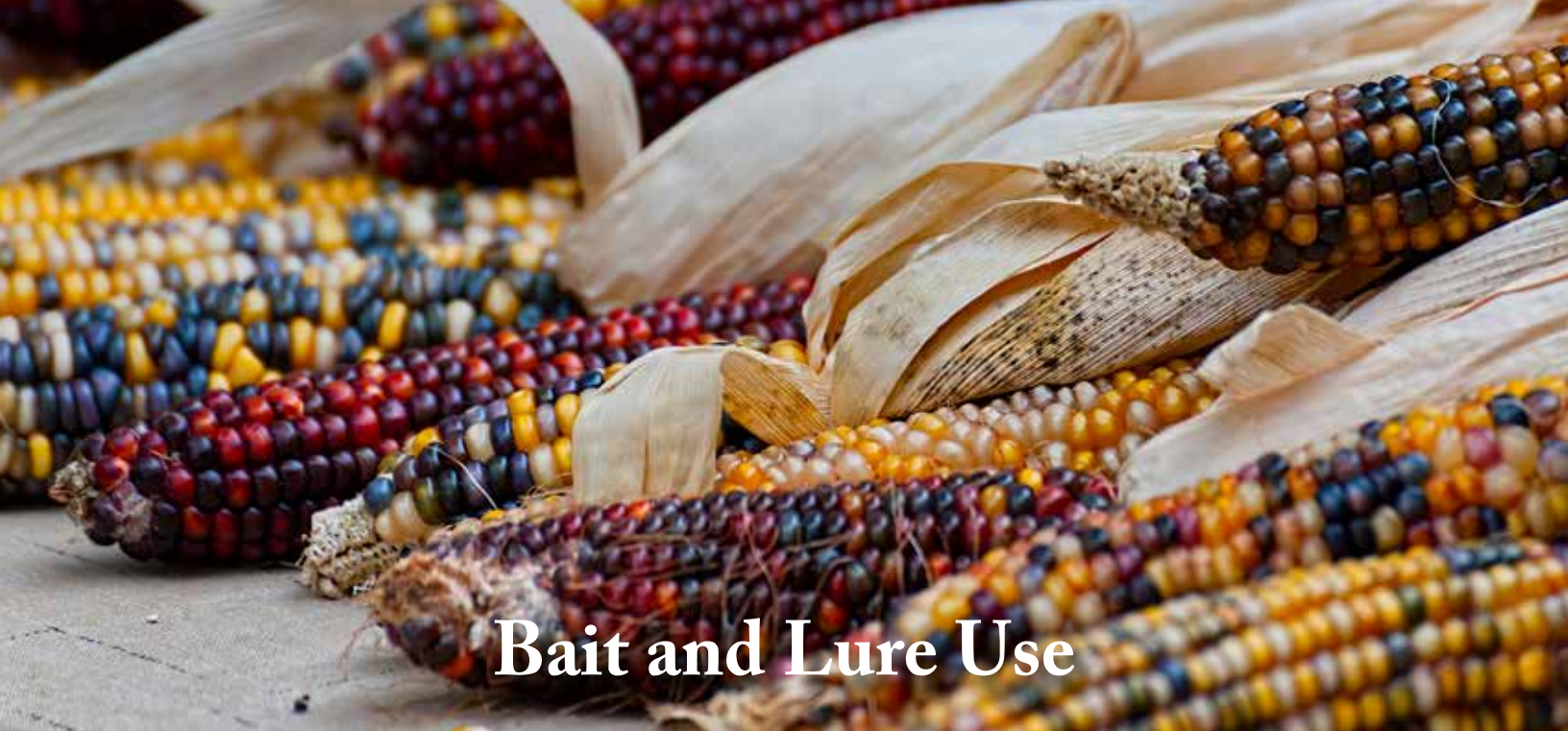

Bait and Lure Use

Not all dryland bodygrip trap sets require the use of baits or lures, but baits and lures are preferable and necessary for some species, sets and locations. For every species, multiple bait and lure choices exist. No attractant or set is 100 percent selective, but some are more selective than others.

Trappers have found that a wide variety of meat and fish-based baits including fish oil and gland lures are often of interest to furbearers. However, baits and lures composed of animal parts, or using feathers, fur, or bone as a visual attractant at the set, are also generally attractive to dogs and cats. For more carnivorous species like bobcat, there may not be any attractive bait or lure that is not also attractive to domestic cats or dogs. However, for herbivorous or more omnivorous species like raccoon, bait and lure choice can be an important consideration in set selectivity.



Many trappers have good success with attractants that are fruit, nut or sweet based compounds. Examples used individually or in combination might include marshmallows, caramel or strawberry spread, maple or corn syrup, molasses, honey, or grains such as milo or corn. Numerous commercially made sweet baits and lures are also available specifically for the purpose of avoiding dogs and cats. One way to use selective baits effectively when setting bodygrip traps in cubbies is to place a potent, broadly attractive lure near the set to attract an animal to the trap area, but use only a more selective bait or lure inside the cubby. For example, a skunky long distance call or gland-based lure attractive to many species could be placed on a tree near the set. Then a sweet or grain based bait less attractive to carnivores, including dogs, yet still attractive to raccoon is placed inside the cubby. Or in the case of marten and fisher, a sweet lure or bait or even a mouse nest could be placed inside the cubby. With this set, various species may be attracted to the area, but the target furbearer species are most likely to actually work the set.

As a rule, reputable bait and lure makers have invested considerable time and energy in formulating, compounding, and testing products, and that knowledge results in the development of products that function in the most effective and selective way. However, there is still a need for scientists to conduct experiments with baits and lures to determine just how selective they are, perhaps allowing recommendations to be refined. Anecdotal experience indicates some small percentage of dogs may be attracted, at least occasionally, to nearly any bait. As such, a realistic expectation with selective baits is that most of the nontargets will not be attracted most of the time. As with other selectivity options, selective baits and lures should be considered insurance against nontarget capture, but not a guarantee.

Sometimes trappers also enjoy experimenting with baits and lures. Evaluating the response of various pets to the attractant is one option. Placing trail cameras near mock trap sets with different baits or lures can be another great way to experiment and learn more about animal responses to different attractants. Functional bodygrip sets are not the place for this type of experimentation.

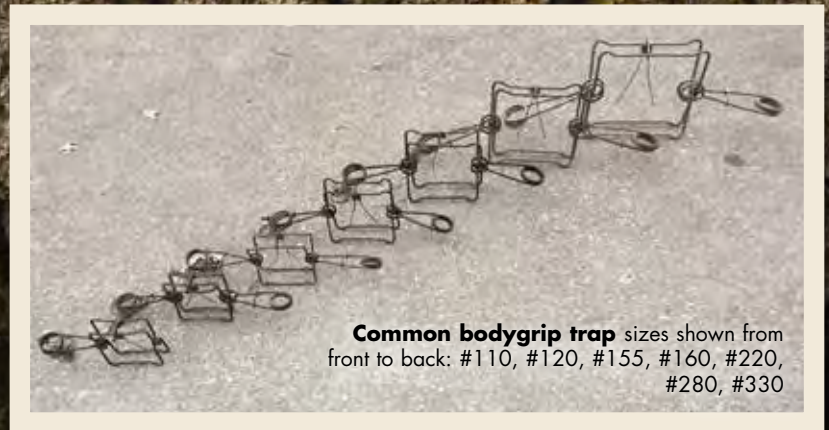
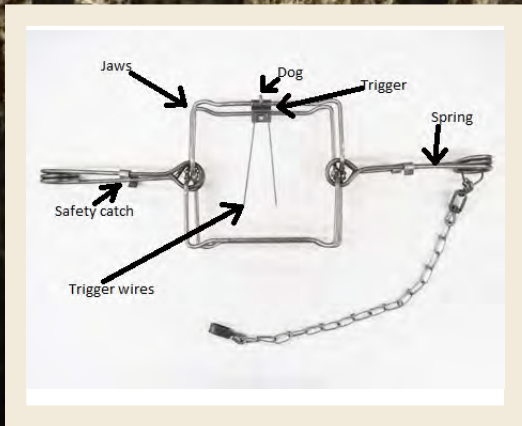

Trap Size

Bodygrip traps come in a variety of sizes, which are based on the size of the primary species for which they are intended (Table 1). However, most species can be caught in multiple trap sizes. For example, the species trappers target with #220s can usually be caught in #160s as well. This is an important consideration. Though just 1 inch smaller in dimensions, the interior area of the #160 is 25 percent smaller than that of the #220. Smaller traps are generally considered preferable to larger ones in terms of selectivity because a dog may be less likely to enter the smaller space, and if it does spring the trap, the smaller trap may be less likely to enclose enough of the dog's head to be a lethal threat. One must recognize though, that smaller traps will not deter same-size nontargets like beagles or terriers from entering a raccoon set. Sometimes even large dogs have been caught in #160s, so trap size alone should not be considered a complete deterrent. In addition, there may be some loss of efficiency when using the smaller trap. Preliminary research is not conclusive but seems to support the assertion of some trappers that some raccoons, perhaps the largest, are more likely to refuse entry into #160s than #220s. Additional research is needed on this subject.

Table 1. Common bodygrip trap models, sizes and target species for which they meet BMP criteria as of April, 2017.

Model ¹	Approx. size (in) ¹	Approx. Area (sq. in.)	Species
#110	4.5x4.5	20.25	Mink ² , muskrat
#120	4.5x4.5	20.25	Marten, fisher ³ , mink ³ , muskrat
#155	5x5	25	Ringtail, raccoon
#160	6x6	36	Fisher ³ , nutria, raccoon, striped skunk
#220	7x7	49	Beaver, fisher ³ , mink, muskrat, nutria, raccoon, river otter ^{2,3} , striped skunk, swift/kit fox
#280	8.5x8.5	72.25	Beaver, river otter
#330	10x10	100	Beaver, river otter

¹ Model names and sizes represent industry standards but not legal mandates

² Passed for submersion sets only

³ Only magnum traps meet BMP criteria

Trigger Type, Position and Shape

The triggering component of a bodygrip trap may play a role in the trap's selectivity in some situations. Various trigger configurations and types are available, but most were developed with the intent of capture efficiency, and their role in terms of selectivity has not been well evaluated.

Trigger type – Common commercially available options include wire triggers or pans. Standard wire triggers are used for most species. Some wire triggers are tension adjustable (see Figures 1A & 1C). They can be tightened onto the trap jaw to require a desired force be applied to the trigger to spring the trap. This is the same concept as adding “pan tension” to a foothold trap, and may be useful in avoiding nontarget animals smaller than the target animal. However, nontarget animals similar in size or larger than the target animal would likely be capable of exerting the force needed to spring the trap. Riveted triggers are not tension adjustable (Figure 1B). Trigger tension is also impractical for smaller species like mink and marten that are sensitive to forcefully pressing against the trigger. In fact, commercially available trigger wire kits consisting of very fine wire can be attached to standard wire triggers in an attempt to increase the likelihood these species will spring the trap when they pass through.

Triggers can be 1-, 2- or 4-way. One-way triggers are used at den sites and prevent an animal outside the den from springing the trap. Two-way triggers are designed to spring only when an animal moves perpendicular into the trap, whereas 4-way triggers (Figure 1C) are designed to also allow the trap to spring when pressure is applied to any side of the trigger.

Trap pans can be added to bodygrip traps so the trap springs when the animal steps on the pan rather than having to push against a wire trigger (Figure 2). Pans may limit refusals by creating an open view into the box or through the trap, and may be preferred for species that may resist pressing against a trigger (like mink, marten and bobcat) and provided their use still produces the desirable strike location (see “strike locations” next page). Pans are primarily used for efficiency of capture, and their role in terms of selectivity has not been well researched. On one hand, a trap set with a pan may be less likely to spring during casual investigation of the set by a dog or other nontarget animal. On the other hand, a trap with a pan may only spring when the head of a dog or other animal is well into the trap, resulting in the lethal capture of an animal that may have been avoided had the trap sprung upon initial investigation of a trap with a wire trigger.

There are several specialty trigger types that incorporate bait directly into the trigger system. One design primarily intended for beaver includes a screw to which a beaver selective bait stick can be attached. Another design which recently became commercially available was developed as a raccoon trap intended specifically to prevent the capture of dogs. This system includes a pull-type trigger, similar in concept to various dog-proof foot-enclosing raccoon traps (Figure 3). The efficiency of this system has not been evaluated through BMP research, and at one to two times the cost of the trap itself, cost may be somewhat prohibitive to large-scale use, but the concept may have promise in some situations as a selective alternative to standard bodygrip trap sets for raccoon.

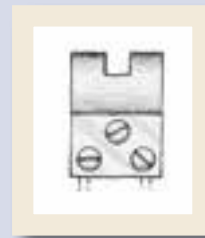

Figure 1A. Square notch tension adjustable trigger; 1 or 2 way



Figure 1B. Square notch non-adjustable tension (riveted) trigger; 1 or 2 way

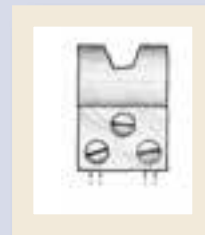

Figure 1C. V-notch four-way tension adjustable trigger

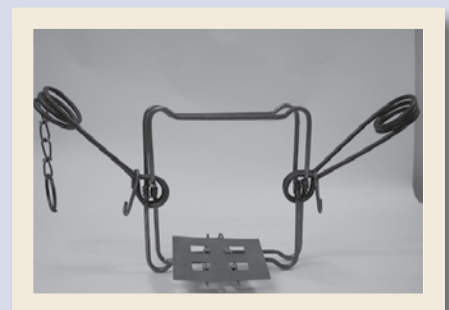

Figure 2. Bodygrip trap with pan-trigger



Figure 3. Sonny's® #220 bodygrip dog proof box*

* As seen in Trapper's Post - July/August 2016

Trigger Postions

One of the advantages of standard wire bodygrip trap triggers is the ease of adjusting trigger position and shape. The trigger easily slides side to side, and can be placed on the top, bottom or side of the trap by setting the trap in different positions. The side trigger position, which is most often used in underwater beaver or muskrat sets, results in less lethal side to side strike locations. It is inadvisable in land sets.

The shape of the trigger is easily adjusted by bending the wires into different positions. The trigger can be placed in the middle or near the left or right edge of the jaw. It can be left long or clipped short. Attempts have been made to identify a trigger position and shape that can be used by beaver trappers to reduce otter captures (Gotie et al. 2000), but additional research is needed on this subject. Beaver trappers recognize that keeping trigger wires out of the lower middle part of the trap can help avoid muskrats.

Less is certain about the performance of various trigger positions and shapes used in dryland sets, particularly as it relates to avoiding dogs. One recommendation based on speculation is to place the trigger wires near the top center of the trap in a standard inverted "V" or "U" shape (Figure 4) so that the animal springs the trap with its nose before getting far into the trap. The idea is that the furbearers for which the traps are intended will be readily captured by the head, but dogs larger than the target wildlife may not have their head into the trap far enough to be held if they do spring the trap. Conversely, trigger wires offset far to one side of the trap may reduce the likelihood of contact during casual investigation, but also may create a more lethal scenario for larger animals by not springing until the animal's head is well into the trap. Additional research is needed on this subject.

Strike locations

Trap size and trigger configuration are important components in achieving proper strike location and a quick kill. Bodygrip traps that are too large for the species being trapped, or trigger configurations that allow the animal to get too far into the trap before firing can result in strike locations across the shoulders, abdomen, or hips, which may result in prolonged death or may even be non-lethal. Alternatively, when traps that are too small for a given species are used, trigger configurations that fire before the animal's head is into the trap may result in a mis-fire or strike that allows the animal to pull out.

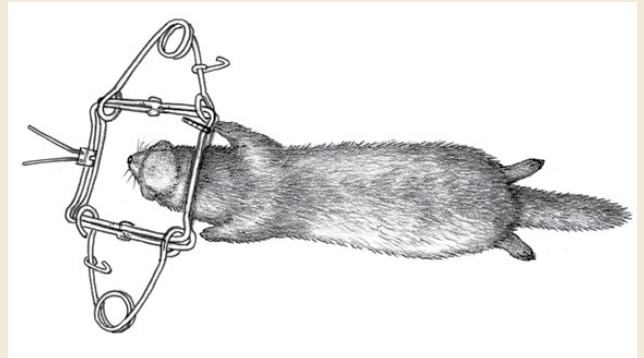

Proper single strike location

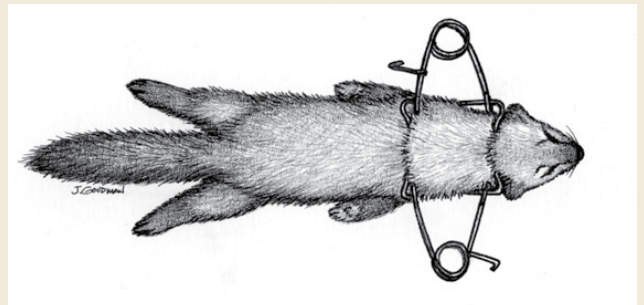

Proper double strike locations



Figure 4. Typical trigger configurations; placement is top center and shape is inverted "U" or "V."

Trap Set Type

Where legal, standard bucket or box sets are often the most commonly used dryland bodygrip trap sets (Figure 5). These sets are used with bait and/or lure, and they are effective. However, the exposed trap at the entrance to these sets is easily accessible to dogs and other nontarget animals that may be showing even minimal interest in the attractant.

Sets can rarely be considered 100 percent selective, and caution is always required when using traps that are intended to kill. However, there are a variety of alternative sets intended to reduce the chance of a nontarget capture, while remaining effective at capturing furbearers. Most of these sets were designed with the specific intent of avoiding dogs, and rely on some form of recessing the trap back into the set. Informal research has shown that most dogs are hesitant to enter a cubby beyond their ears. They may stick their snout into a cubby, but don't like to place their entire head or beyond into a compact space. The recommended distances in which traps are recessed into the cubby, which varies according to the size of the opening or entry, is based upon the distance from the tip of the nose to the back of the ears of common hunting dog breeds, and experimentation of how far different sized dogs would enter cubby openings of different sizes.

Other set types are intended to physically prevent access to dogs. Entering these sets requires maneuverability that most dogs don't possess (vertical cubbies) or the ability to climb (elevated cubbies). Raccoon, marten and other furbearers that naturally inhabit dens are accustomed to climbing and entering tight spaces, and have the ability to work these sets.

Most of these set types were developed by trappers based on sensible observation. To date, little scientific research has evaluated the selectivity, efficiency, or practical application of these sets, but most have shown great promise in reducing non-target captures, especially when used in conjunction with selective baits or lures. In the future, it is expected that the scientific wildlife community will apply rigorous testing to evaluate the performance of these sets. Until then, we offer the set types described below as options that may help improve selectivity, and may reduce conflicts caused by non-target captures.

#160 bucket set: The bucket commonly used to make the #220 set also fits the #160, but the trap goes in the bottom of the bucket rather than the top (Figure 6). The set is constructed by placing the lid on the bucket and cutting out the bottom, screwing a small piece of lathe onto the front bottom of the bucket, and cutting a couple 2 inch spring channels. The smaller size of the #160 (compared to the #220) reduces the chances that a medium or larger dog will be captured should one spring the trap, yet this trap will catch even the largest of raccoons.

Recessed bucket set with wire enclosure: This set is easily constructed by attaching a wire enclosure to the front of the bucket (Figure 7). It can be made with either the #220 or #160 bucket set. The enclosure is constructed by folding a single piece of wire into thirds (10x27 inches for the #220 and 8x24 inches for the #160). Cut 3x6 inch spring slots into the side, and attach to the top of the bucket with wire or hog rings so the enclosure can be flipped up to allow access to the trap. The wire must be staked down so that it cannot flip up. Several variations of these "lid-on" bucket sets exist, but those where the lid does not cover the spring slot are easiest for the trapper to work with.



Figure 5. Standard #220 bucket and box sets with non-recessed trap



Figure 6. 160 bucket set



Figure 7. Recessed bucket set with wire enclosure

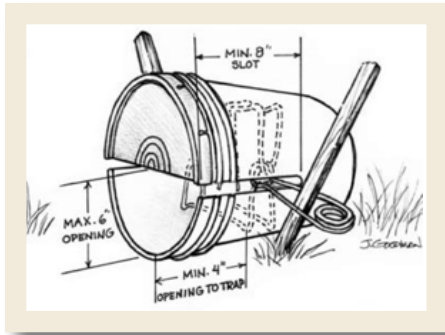

Figure 8. Restricted entry 5-gallon bucket set



Figure 9. Restricted entry bucket set

Restricted entry bucket sets: Both of these sets are designed primarily for use with the #220 bodygrip trap. Existing bucket sets are easily modified in this manner. For the 5-gallon bucket set, the lid should be cut off even with the top of the spring slots (Figure 8). For the square pail, a 3-inch section of lid should be placed back onto the bucket, creating a 7-inch tall entry (Figure 9). For both buckets, 8-inch spring slots should be cut, and the trap should be staked 4 inches from the opening. This will allow the trap to spring without being propelled into the lid. Have some extra lids prepared in case one is damaged or lost. Several variations of these "lid-on" bucket sets exist, but those where the lid does not cover the spring slot are easiest for the trapper to work with.



Figure 10. Standard recessed box cubby set

Recessed box cubby sets: Several designs of recessed box cubbies exist. In general, the larger the trap and the cubby opening, the farther into the cubby the trap should be recessed. For example, a #160 might be recessed 7 inches whereas a #220 might be recessed 11 inches. The concept is that the trap is placed back into the box rather than at the entrance (Figure 10).

Another example would be an 8-inch recess for a 50 square inch opening (just over 7x7 inches), an 11-inch recess for an 80 square inch opening (8x10 inch), or an 18-inch recess for a 100 square inch opening (10x10 inch). The size of the cubby entrance can be reduced (see Figures 8, 9 & 11) so the trap doesn't need to be set back so far by covering a portion of the top with a board or wire.

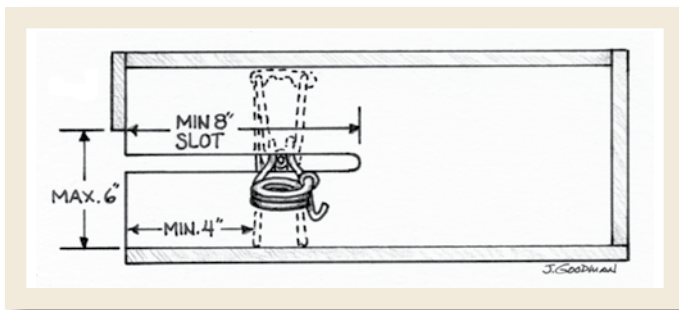

Figure 11. Box cubby with "mid-slot" trap

Another consideration is that the trap can be set closer to the cubby entrance as long as it's placed in the middle rather than at the back of the spring slot (Figure 11). For example, a #220 should be set 4 inches back in an 8-inch spring slot (in a cubby with a 6-inch high opening). The basis for this is that a trap is propelled forward when sprung if set so the springs are in contact with the back of the slot, whereas the trap will basically close in position if the spring is allowed space in the slot to decompress. The trap needs to be securely anchored with the trigger centered on top, and bait or lure should be placed at least 6 inches beyond the trap.



Figure 12. Box cubby with extended roof

A box cubby with an extended roof has been effective and selective for some trappers in a state where recessing is not mandatory (Figure 12). It has 6-inch spring slots and a roof that extends 7-12 inches beyond the entrance. The effectiveness and selectivity of this design has not been scientifically compared with complete-box designs above. The cubby should be staked so it can't be flipped, allowing access to the trap.

Vertical box cubby: This set (Figure 13) can be rapidly deployed, rebaited, and reset after a capture, similar to or even quicker than standard bucket or box sets. It can be screwed or nailed to a tree or post, or it can be wired through holes drilled in the back below the bait shelf. Proper attachment of the wooden top allows easy access to the bait shelf (Figure 14).

The box can be small, as short as 15 inches or even 12 inches tall, making it easy to handle. Because the raccoon must stand in order to reach upward – and it is captured when it stands, reaching in is not a problem with this set as it could be with using a short box on the ground. The trap chain can be secured to the wire or nails used to attach the box to the tree. No time is spent staking the set or the trap.

The bottom of the set should be placed no more than 6 inches off the ground (see Smith 2003). Raccoons can enter these types of sets even down to 4 inches or less off the ground. A tree that doesn't flare out too much at the bottom is required. The trap is held in place by spring pressure. Bait is placed on the bait shelf, and a trailing scent from the base of the box to a nearby trail completes the set.

A similar alternative to this set can be made by raising the bottom of the cubby 4-6 feet off the ground (enough to be inaccessible to dogs). This elevated bottom-entry vertical box cubby set can be used for fisher, marten and even raccoon though the set may not be as effective as other set types for raccoon.

Elevated top entry box cubby set: This set is versatile and can be used for raccoon, marten and fisher. It requires an 18-24 inch long #220 cubby with 8-inch spring slots. A wire mesh back (bottom) should be placed on the box, as well as a plywood top with a circular 6-inch diameter entry hole (Figure 15), (see Palas 2012). This top needs to open when a catch is made, and can use the same system described in the vertical box cubby set (Figure 14).

Palas suggested that the top of the box be placed 6 feet off the ground or higher if required to be legal. The box can be attached to a tree in the same manner as the vertical box cubby. The bait should be covered with grass or leaf litter to hide from overhead view by birds. The top of the box also helps hide the bait and gives raccoons a place to perch before entering the box.

Multiple states prohibit #160 and/or #220 bodygrip traps from dryland sets unless they are raised 4-6 feet off the ground. This set is one of the few legal options for trappers in those states.

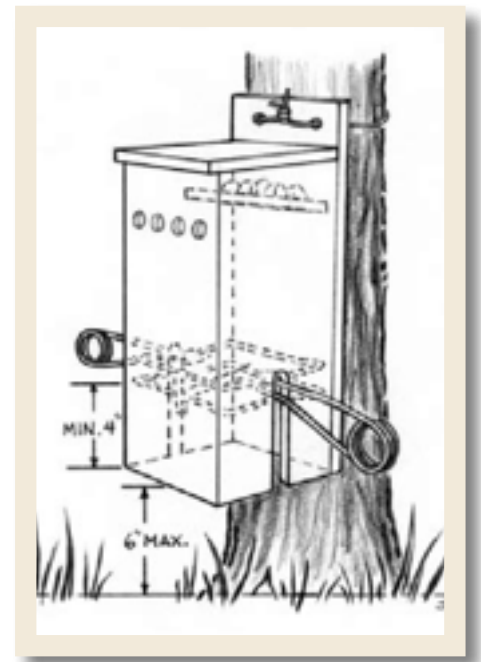

Figure 13. Vertical box cubby



Figure 14. For easy access to bait shelf, place a single screw in front corner of lid and a bent nail in back corner (see white arrows). Rotate nail to allow top to swing open.



Figure 15. For Elevated top entry box cubby set; showing top (left) and bottom (right)

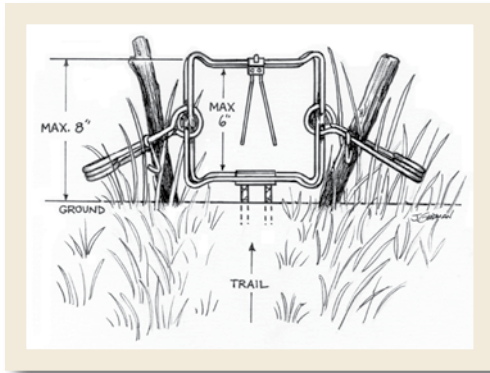

Figure 16. Typical trail set without enclosure



Figure 17. Wire trail set enclosure

Trail sets: Trail sets intended for raccoon are usually not considered high risk sets, because most large dogs will jump over the set. However, trail sets do not prevent small dogs such as beagles or terriers that are similar in size to raccoons from being captured, and as such, may actually be less selective against this size of dog than cubby sets used with sweet baits or lures.

There are several approaches to improving the selectivity of trail sets for larger dogs. First, the higher the trap is off the ground, the larger the dog that may be susceptible to capture. In general, the trap should not be more than a couple of inches off the ground. Some states specify that a non-baited trail set must be placed so that no part of the surface is more than a certain height (e.g., 8 inches) off the ground (Figure 16).

Another approach is to cover the set with wire mesh (Figure 17). A user-friendly cover can be made with a single 16 X 30 inch piece of wire with 5 X 8 inch gaps cut out of the center bottom to accommodate the trap springs. The cover can be camouflaged with vegetation from the area to create a protected travel-way that is inviting to furbearers. "Jump sticks" are another option that may encourage a dog to raise its head and go over or around a trail set (Figure 18).

A common trail set location is where a trail passes under an obstacle such as woven wire fence where there is no other way through or around. By setting the trap under the fence, a dog or any other nontarget animal coming down the trail is forced into the trap. By setting the trap in the trail 5 or 6 feet in front of the fence rather than under the fence, larger nontarget animals like some dogs will be able to pass under the fence then go over or around the trap, whereas target-sized animals like raccoon, opossum and skunk will still be funneled by the trail into the trap (Figure 19).

Trail sets are usually made without any bait or scent. However, the use of trailing scent is sometimes used to lead the animal into the set. Trappers should realize this may increase the chance that a larger dog will enter the set with its head down and be captured, so the use of jump sticks or wire enclosures should be considered when using trailing scents. The use of scents that are not attractive to dogs will help prevent this from occurring as well.

A recommendation of some trappers who use trail sets is to move the set down the trail a bit after each capture to get away from the scent of any animal previously captured, especially raccoons. These trappers believe raccoons avoid the location where another raccoon was killed, and that moving the set will help them catch more raccoons. Moving the set may also help avoid a dog with its head down sniffing where the dead raccoon was.



Figure 18. Trail set showing jump sticks



Figure 19. Obstacle cross under set (trap needs to be camouflaged with vegetation to complete set)

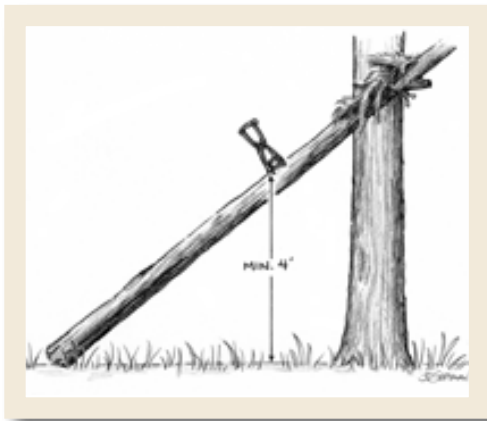

Figure 20. Leaning pole set



Figure 21. Leaning pole set with use of a cubby box

Leaning pole set: This type of set is commonly used for marten and fisher. The trap and bait can be placed directly on the pole (Figure 20) or inside a box cubby (Figure 21). Bait should be covered to avoid unwanted attention of birds if not placed in a cubby box.

Where Canada lynx may be present and are protected, trappers need to be aware of specific regulations that vary by state. In general, bodygrip sets that might take a lynx are prohibited. Regulations applying to leaning pole sets are meant to allow trappers to continue to target marten or fisher while selectively avoiding lynx. In general, the pole should be no larger than 4 or 6 inches in diameter. Some states require it to be set at a 45 degree or greater angle to the ground, and the trap and bait should be placed at least 3 to 4 feet above the ground or snow level.



Figure 22. Lynx exclusion device

Lynx exclusion device: One option that allows trappers in Maine to set medium sized bodygrip traps on land consists of a wire or box cubby with a top or side entry (not directly in front of the trap), and a deeply enclosed trap (Figure 22). However, trappers have expressed concern that these enclosures also greatly reduce capture of their target species (Noonan, 2016).

Wolverine exclusion: Where wolverine may be present and are protected, bait should be placed at least 4 feet above the ground, the leaning pole should be no more than 4 inches in diameter, and the pole should be set at a 45 degree angle or greater. The smaller pole and steeper angle may discourage climbing by a wolverine, but will not discourage marten or fisher. Using the smallest traps suitable for marten (size #120; 4.5 x 4.5 inches) and fisher (size #120 or #155; 5 x 5 inches) is recommended, and traps should be securely anchored, as wolverine may be able to pull out of smaller bodygrips, especially if caught by the foot.

Other Considerations: Weight can be a concern with some of the bigger boxes. Three-quarter inch wood is often used on the sides. Using ¼ inch wood on the top and bottom will reduce weight (Figure 23). Some trappers even prefer to leave the bottom open with just a piece of lathe at the front and back of the box for support. This also saves the trapper time at the set, by not having to camouflage the bottom of the box, and it may even reduce refusals of recessed sets as an animal doesn't have to walk on wood to get to the trap. Another way to reduce weight and possibly make the set more effective is to use wire rather than wood on the back of the box (Figure 24). Some trappers believe this creates better air flow and scent dispersal, and that an animal that can see through the box is more likely to enter. Most of the traps and cubbies in this document are shown in the open to enhance visibility. Trappers often prefer to camouflage the set with vegetation to make it look like a natural cubby (Figure 25).



Figure 23. Reduced weight box cubby



Figure 24. Box cubby with wire mesh back



Figure 25. Camouflaged cubby set



Guides on how to avoid incidental take of both lynx and wolverine can be found at these links:

Lynx:

http://www.fishwildlife.org/files/How_to_Avoid_Incidental_Take_of_Lynx.pdf

Wolverine:

http://www.fishwildlife.org/files/WolverineAvoidance_June2013.pdf

Note on bobcat sets:

Because bobcats are a larger animal, some variations of bobcat bodygrip cubby sets have raised entrances to encourage bobcat entry. However, this technique also increases risk to dogs. For the most part, bodygrip sets that are attractive to bobcats but exclude or deter dogs have not been developed. Therefore, it is critically important to choose bodygrip set locations for bobcats that are unlikely to be encountered by pets. Bodygrip trap sets that are attractive to bobcats also appeal to lynx and are typically prohibited where lynx may be present and are protected.

Hunter Awareness

This document is primarily focused on things trappers can do to avoid conflict while trapping. When the conflict involves a hunting dog, hunters are also part of the equation. As such, they should take some basic precautions to help protect their own interests. First, they should have a general awareness of trapping. They should know when and where trapping may occur, so they are not surprised if they encounter a trap or a trapped animal. They should know what different trap sets look like, so if they do encounter them, they can help their dog avoid them. They should also know how to release their dog from different trap types, so they can safely assist their dog if it is captured.

Wildlife agencies should assist in this process by providing hunters with this information. Several wildlife agencies have developed brochures or information intended to inform hunters on this subject:

- Alaska:** <http://www.adfg.alaska.gov/index.cfm?adfg=trapping.sharing>
- Idaho:** <http://fishandgame.idaho.gov/public/hunt/trappedPetBrochure.pdf>
- Kansas:** <http://ksoutdoors.com/Hunting/Hunting-Regulations> (see pages 36-37)
- Montana:** <http://fwpiis.mt.gov/content/getItem.aspx?id=32308>
- North Dakota:** <http://gf.nd.gov/hunting/trapping-and-dogs>
- Nova Scotia:** <http://www.novascotia.ca/natr/wildlife/doc/PetOwners.pdf>
- Wisconsin:** <http://dnr.wi.gov/topic/trap/documents/bodygripbrochure.pdf>



Figure 26. Self-locking bodygrip trap setter

The easiest way for most people to release an animal from a bodygrip trap is with the use of a scissor-type self-locking bodygrip setter (Figure 26). These can be purchased from most any trap supplier. Alternatively, the Minnesota Trappers Association has developed a technique to release an animal from a bodygrip trip using large zip ties. A hunter can easily carry a couple of these in a game vest. This technique was developed as an improvement over the "rope method" of release described in several of the agency publications above. Information on the technique can be found at this link: http://www.mntrappers.org/_fileCabinet//bodygrip.pdf

Last, one option that is rarely considered is to train a dog to avoid traps. Many trappers use dogs on their line that have learned to avoid traps, and most coyote trappers recognize how difficult it can be to entice an educated canine into a set. By letting a dog work various sets and then providing negative stimuli, a dog can be trained to avoid most traps. This may be especially effective against bodygrip buckets or cubbies, which are usually visible and obvious. All hunting dogs range out of sight at least occasionally, so this may be a reasonable consideration for any hunter, but this effort may be most worthwhile for hunters with dogs that typically range far and wide.

Conclusion

Bodygrip traps are important tools for harvesting furbearers and managing wildlife populations throughout North America. When used appropriately, they are efficient, humane, selective, and safe. However, irresponsible use of these devices can lead to restrictions in their use and can negatively affect wildlife management programs. It is important that trappers are aware of the techniques that can be used to maximize the selectivity of these devices, and exercise good judgment in their use. Additional research is needed to better understand the effectiveness of measures used to increase the selectivity of bodygrip traps.



References

Association of Fish and Wildlife Agencies. 2015. *Best Management Practices for Trapping in the United States*. Washington, D.C. http://fishwildlife.org/?section=best_management_practices

Golden, H, and T. Krause. 2003. *How to avoid incidental take of lynx while trapping or hunting bobcats and other furbearers*. Joint publication of the U.S. Fish and Wildlife Service and the Association of Fish and Wildlife Agencies. Washington, DC. http://www.fishwildlife.org/files/How_to_Avoid_Incidental_Take_of_Lynx.pdf

Gotie, R, M. Kautz, M. Brown, and E. Kautz. 2000. Selectivity with #330 Conibears. *Trapper and Predator Caller*. Oct., 2000.

Hiller, T.L., and H.B. White. 2013. *How to avoid incidental take of wolverine during regulated trapping activities*. Association of Fish and Wildlife Agencies, Washington, DC. http://www.fishwildlife.org/files/WolverineAvoidance_June2013.pdf

International Organization for Standardization ("ISO") TC191. 1998. *Trap testing methods*. ISO, TC191-4, 5. International Organization for Standardization. Geneva.

International Organization for Standardization ("ISO") 10990-4:1999(E). 1999. *Animal (mammal) traps- Part 4: Methods for testing killing trap systems used on land or underwater*. International Organization for Standardization. Geneva.

Noonan, B. 2016. Lynx Protection? Maine devices exclude more than lynx. *Trapper's Post*. Volume 8, No.1. Sept./Oct., 2016.

Palas, Mark. 2012. Trapping: Raccoons up in the Trees. *Fur-Fish-Game*. Sept., 2012.

Responsive Management. 2005. *Ownership and use of traps by trappers in the United States in 2004*. Responsive Management, Harrisonburg, Virginia, USA. 110 pp. <http://www.fishwildlife.org/files/AFWA-FINAL-TRAPPING-Report.pdf>

Responsive Management. 2015. *Trap Use, Furbearers Trapped, and Trapper Characteristics in the United States in 2015*. Responsive Management, Harrisonburg, Virginia, USA. 268 pp. http://www.fishwildlife.org/files/AFWA_Trap_Use_Report_2015_ed_2016_02_29.pdf

Smith, S. 2003. *A better way of trapping raccoons*. Furbearer Management News. New York State Department of Environmental Conservation. Albany, NY.

White, H. B., T. Decker, M.J. O'Brien, J.F. Organ, and N.M. Roberts. 2015. *Trapping and furbearer management in North American Wildlife Conservation*. *International Journal of Environmental Studies*, DOI: 10.1080/00207233.2015.1019297. <http://www.tandfonline.com/doi/full/10.1080/00207233.2015.1019297>



ASSOCIATION *of*
FISH & WILDLIFE
AGENCIES

Furbearer Conservation
Technical Work Group